

# Model 845 Specification 2.47

Portable 12, 20, & 26.5 GHz Microwave Signal Generator

with options HP, PE, R, LN, FS & LO



**BNC**

**Berkeley Nucleonics**

Test, Measurement and Nuclear Instrumentation since 1963

## Introduction

The Model 845 Series is a series of low-noise and fast-switching microwave signal generators covering a continuous frequency ranges from as low as 100 kHz up to 12, 20, and 26.5 GHz, respectively, with a 0.001 Hz resolution.

The 845 Series provide an accurately levelled output power range and high spurious suppression. Advanced frequency synthesis with fractional-N divider makes for low SSB phase noise and micro-Hz resolution.

Available Options:

- HP** delivers higher maximum output power to a level up to +27 dBm.
- PE** is an optional power level extension to accurately level below -90 dBm.
- LN** provides ultra low phase noise and further improves frequency stability
- FS** substantially reduces the switching speed
- LO** removes all built-in modulation capabilities if not needed (845-20, 845-26 only)
- RB** adds an internal rechargeable battery module
- R** modifies form-factor to a 19" rack-mountable 1HU enclosure
- TP** modifies form-factor to a 3HU 19" bench-top enclosure with touch-display control

The standard Model 845 includes amplitude modulation (AM), DC-coupled, low distortion wideband frequency modulation (FM), PM, FSK and PSK, frequency chirp, and fast pulse modulation with internal pulse train generator. Three internal modulations sources are available.

All modulation modes of the Model 845 can be combined. This allows the generation of complex modulation signals for modern communication and location systems. The combination of pulse modulation and FM simulates Doppler effects or chirp signals. Simultaneous AM and pulse modulation provides the types of signal occurring in pulse radar applications with rotating antenna. The combination of FM and AM can be used to check fading effects of FM receivers.

All Model 845 allow fast analog and digital sweeps including flexible list sweeps, where frequency, power and dwell times can be set individually. A flexible triggering capability simplifies synchronization within test environments.

All Model 845's operate with an ultra-stable temperature compensated 100 MHz reference (OCXO) to ensure minimal drift, and can be phase-locked to any stable external reference in a range from 1 to 250 MHz. Additionally, optimum phase synchronous signals can be achieved by bypassing internal and feeding a 100 MHz signal directly as reference. The Model 845 supports various standard interfaces such as USB-TMC, LAN, and GPIB.

Applications for the Model 845 Series include

- R&D low noise microwave source
- Production testing (industry-leading switching times; high dynamic range)
- Service and maintenance (battery operation)
- Signal simulation (Radar, WiMax, UWB)
- Aerospace & Defence (Pulse modulator, Chirps)

## Signal Specifications

The specifications in the following pages describe the warranted performance of the signal generator for  $23 \pm 10^\circ\text{C}$  after a 30 minute warm-up period and for all configurations (options PE3 if not explicitly stated). Typical specifications describe expected, but not warranted performance. Min and Max specifications are warranted.

Parameter	Min.	Typ.	Max.	Note
<b>CW mode</b>				
Frequency range	100 kHz 100 kHz 100 kHz		12.0 GHz 20.0 GHz 26.5 GHz	<b>845-12</b> <b>845-20 , settable to 20.5 GHz</b> <b>845-26, settable to 30 GHz</b>
resolution		0.001 Hz		
Phase resolution		0.1 deg		
Frequency / Amplitude settling time		200 $\mu\text{s}$	300 $\mu\text{s}$ 30 $\mu\text{s}$	time from receipt of SCPI command option FS
<b>SSB Phase noise (standard)</b>				
<b>500 MHz</b>				
10 Hz offset		-74 dBc/Hz		
1kHz offset		-126 dBc/Hz		
100 kHz offset		-137 dBc/Hz		
<b>4 GHz</b>				
10 Hz offset		-68 dBc/Hz		
1kHz offset		-108 dBc/Hz		
100 kHz offset		-119 dBc/Hz		
<b>20 GHz</b>				
10 Hz offset		-51 dBc/Hz		
1kHz offset		-91 dBc/Hz		
100 kHz offset		-104 dBc/Hz		
Wideband noise		-150 dBc/ Hz		
<b>SSB Phase noise (option LN)</b>				
<b>500 MHz</b>				
10 Hz offset		-106 dBc/Hz		
1kHz offset		-131 dBc/Hz		
100 kHz offset		-147 dBc/Hz		
<b>4 GHz</b>				
10 Hz offset		-88 dBc/Hz		
1kHz offset		-115 dBc/Hz		
100 kHz offset		-128 dBc/Hz		
<b>20 GHz</b>				
10 Hz offset		-74 dBc/Hz		
1kHz offset		-100 dBc/Hz		
100 kHz offset		-113 dBc/Hz		
<b>Amplitude Noise at 10 GHz</b>		-130 dBc/Hz -140 dBm		Pout=+10 dBm, 100 kHz offset noise floor
<b>Output power</b>				Check maximum output power plots on page 10
<b>Standard</b>				
100 kHz to fmax	-20 dBm		+15 dBm	
<b>Option PE3 only</b>				
100 kHz to fmax	-90 dBm		+13 dBm	

Parameter	Min.	Typ.	Max.	Note
<b>Option HP only</b>	-20 dBm -20 dBm -20 dBm		+25 dBm +23 dBm +18 dBm	0.2 to 10 GHz 10 to 16 GHz, see plot >18 GHz, see plot
<b>Options HP and PE3</b>	-90 dBm -90 dBm -90 dBm -90 dBm		+22 dBm +20 dBm +18 dBm +15 dBm	< 10 GHz 10 to 16 GHz 16 to 20 GHz >20 GHz
<b>Level resolution</b>	0.01 dB			
<b>Level uncertainty, ALC on</b>		0.3 dB 0.6 dB	1.0 dB 1.5 dB 2.5 dB 5.0 dB	-15 to +15 dBm -65 dBm to -15 dBm , option PE3 < -65 dBm, f< 10 GHz option PE3 < -65 dBm, f> 10 GHz option PE3 < -65 dBm, options PE3 & 1URM > 15 dBm to Pmax, option HP
Temperature effects <b>User flatness correction</b>		0.8 dB 0.5 dB  0.015 dB/ °C up to 2000 points	2.0 dB 2.0 dB	0 to 45 °C
<b>Output impedance</b> <b>VSWR</b>	50 Ω 2.0			
<b>Reverse Power Protection</b>				
DC Voltage			±15 V	
RF power			30 dBm	
<b>Spectral purity at + 5 dBm</b>				
Output harmonics		-40 dBc	-30 dBc	See plot
Sub-harmonics		-75 dBc -50 dBc	-65 dBc -40 dBc	< 20 GHz > 20 GHz
Non-harmonic spurious < 312 MHz > 312 to 625 MHz > 625 MHz to 1.5 GHz > 1.5 GHz to 2.5 GHz > 2.5 GHz to 5 GHz > 5 GHz to 10 GHz > 10 GHz to 20 GHz > 20 GHz		-80 dBc -75 dBc -75 dBc -70 dBc -65 dBc -60 dBc -55 dBc -50 dBc	-66 dBc -70 dBc -65 dBc -65 dBc -60 dBc -55 dBc -50 dBc -45 dBc	CW +10 dBm, > 3 kHz offset
Residual FM @ 10 GHz		15 Hz		0.3 kHz to 3 kHz, weighted (ITU-T), RMS
Residual AM @ 10 GHz		0.02 %		RMS value (0.01 kHz to 15 kHz)

## Sweeping Capability

Sweeps can be performed with combined internal or external AM/FM/PM/pulse modulation running. With modulation enabled, the minimum step time increases to 2 ms.

Parameter	Min.	Typ.	Max.	Note
<b>Digital power / frequency / list sweeps</b>				
Sweep type: linear, logarithmic, random				
Step time ( $\tau_{step}$ )	400 $\mu$ s 40 $\mu$ s		19998 s	Option FS
Dwell time ( $\tau_{val}$ )	10 $\mu$ s		9999 s	
Off-time (incl. transient time) ( $t_{off}$ )	0		9999 s	
Transient time ( $\tau_{inv}$ )			270 $\mu$ s 30 $\mu$ s	Option FS
Timing delay ( $\tau_{de}$ )		2 to 10 $\mu$ s 50 ns		Option FS
Time resolution		0.1 $\mu$ s 5 ns		Option FS
Timing accuracy per point		3 $\mu$ s 5 ns		Option FS

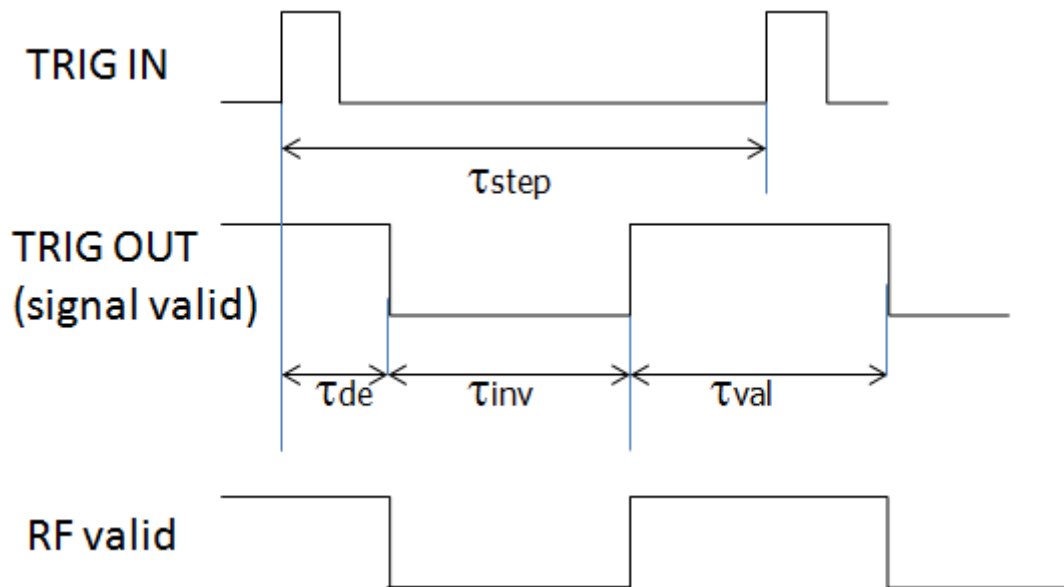

## Frequency Chirps

(linear ramp, up/down)

Bandwidth	10 %			of carrier frequency
Dwell time ( $t_{dwell}$ )	10 ns		10000 $\mu$ s	
Slope			100 MHz / $\mu$ s	
Number of frequencies			65'000	

## Reference Frequency

REF IN input and REF OUT output are at rear panel

Parameter	Min.	Typ.	Max.	Note
Internal reference frequency		100 MHz 10 / 100 MHz		Option LN
Initial accuracy			±40 ppb	calibrated at 23 ± 3 °C at time of calibration , user adjustable
Temperature stability (0 to 50 degC)			±100 ppb ±20 ppb	Option LN
Aging 1 <sup>st</sup> year		0.5 ppm 0.1 ppm		Option LN
Aging per day (after 30days operations)			5 ppb tbm	Option LN
Warm-Up time		5 min		
Output of internal reference		10 MHz 10/100 MHz		
Output power		0 dBm		
Output impedance		50 Ohms		
Bypass Internal reference Input	100 MHz, -5 to +10 dBm 100 MHz, 1 GHz			High phase synchronous mode  Option LN
Phase Lock to External Reference External Input Range	1 MHz		250 MHz	User programmable
Reference input level	-5 dBm	0 dBm	+13 dBm	
Lock Range			±1.5 ppm	
Reference input impedance		50 Ohms		

## Multi Purpose Output (FUNC OUT)

Output is FUNC OUT at rear panel

Parameter	Min.	Typ.	Max.	Note
<b>MULTIFUNCTION GENERATOR</b>	sine, triangle, square wave			
Frequency range	1 Hz 1 Hz		3 MHz 1 MHz 50 kHz	sine triangle square
Frequency resolution		0.1 Hz		
Output voltage amplitude peak-peak	10 mV	5V	2 V	Sine, triangle Square (CMOS output)
Harmonic Distortion		1 %		< 100 kHz, 1 Vpp
Output impedance		50 Ohms CMOS		Sine, triangle square wave
<b>VIDEO OUTPUT (of internal pulse modulator)</b>				
Output		CMOS		
Period	30 ns		50 s	
Pulse Width	15 ns		50 s	

Parameter	Min.	Typ.	Max.	Note
RF delay		10 ns		
<b>TRIGGER OUT</b>	<b>Synchronization mode for multiple sources</b>			
Modes	Trigger on sweep start Trigger on each point Signal Valid			Option FS

## Trigger Input (TRIG IN)

Input is TRIG IN at rear panel

Parameter	Min.	Typ.	Max.	Note
Trigger Types	Continuous, single, gated, gated direction			
Trigger Source	RF key, external, bus (GPIB, LAN, USB)			
Trigger Modes	Continuous free run, trigger and run, reset and run			
Trigger latency		2 $\mu$ s 5 ns		Option FS
Trigger uncertainty		5 $\mu$ s 10 ns		Option FS
External Trigger delay	50 $\mu$ s 50 ns		40 s 10 s	programmable Option FS
External Delay Resolution		15 ns 10 ns		Option FS
Trigger Modulo	1		255	Execute only on Nth trigger event
Trigger Polarity	Rising, falling			

## Trigger Output (TRIG OUT)

see Multi Purpose Output (FUNC OUT)

## Modulation Capabilities (not with option LO)

Combined AM/PM/FM/PULSE possible (see user manual)

Parameter	Min.	Typ.	Max.	Note
<b>Multifunction Generator</b> sine, triangle, square wave Output is FUNC OUT at rear panel				
Frequency range	1 Hz 1 Hz		3 MHz 1 MHz 50 kHz	sine triangle square
Frequency resolution		0.1 Hz		
Output voltage amplitude peak-peak	10 mV	5V	2 V	Sine, triangle Square (CMOS output)
Harmonic Distortion		1 %		< 100 kHz, 1 Vpp
Output impedance		50 Ohms CMOS		Sine, triangle square wave
<b>Pulse Modulation</b>				
On/off ratio		70 dB		<b>at +10 dBm</b>
Repetition frequency	DC		10 MHz	
Pulse width	30 ns 500 ns			ALC hold ALC on
Pulse rise/fall time		7 ns		
Pulse width	30 ns		5 s	
Duty cycle	0.05 %		99.95 %	
Pulse resolution		15 ns		
Polarity		selectable		
External input amplitude		1 V TTL		AC DC
<b>Pulse Pattern Modulation</b>				
On/off ratio		70 dB		Using internal pattern generator <b>at +10 dBm</b>
Pulse bit width	30 ns 500 ns			ALC hold ALC on
Pulse rise/fall time		7 ns		
Programmable pattern length	2		4192	
Pulse width	30 ns		5 s	
Duty cycle	0.05 %		99.95 %	
Pulse bit resolution		15 ns		
Polarity		selectable		
<b>Frequency Modulation</b>				
Maximum Frequency deviation (peak)		> 0.05·f N · 200 MHz		< 1.25 GHz 1.25 GHz to 2.5 GHz (N=0.125) 2.5 GHz to 5 GHz (N=0.25) 5 GHz to 10 GHz (N=0.5) > 10 GHz to 20 GHz (N=1)
Deviation accuracy (1kHz rate, 50 kHz deviation)		< 2%		
Modulation rate	DC		800 kHz	> -3dB frequency response
Modulation waveforms	Sine, triangle, FSK			
External input sensitivity				adjustable for ±1 V range discr. values ; ±5 V range
AC	0 to N · 200 MHz / V			
DC	0 to N · 100 MHz / V			



Parameter	Min.	Typ.	Max.	Note
Total harmonic distortion	< 1%			1 kHz rate & N · 1 MHz deviation
<b>Phase Modulation</b>				
Phase deviation (peak)	0		N-300 rad	
Modulation rate	DC		800 kHz	> -3dB frequency response Max. phase deviation degrades above 20 kHz modulation rate
Modulation waveforms	Sine, triangle, FSK			
External Input sensitivity	Settable 0.1 rad/V to 360 rad/V			
Total harmonic distortion	< 1%			1 kHz rate & N x 100 rad deviation
<b>Amplitude Modulation</b>				
Modulation rate	0.1 Hz		50 kHz	
Modulation waveforms	Sine, triangle, square			
Modulation depth	0 %		90 %	
Distortion (sine wave)		2 %		at 60% modulation depth
Accuracy (1kHz, 80%)	- 4%		4 %	for 10 to 80%, 0 dBm

Notes:

## Typical performance curves

Phase Noise Performance (10 Hz to 50 MHz offset) at 1,4,13 and 26 GHz

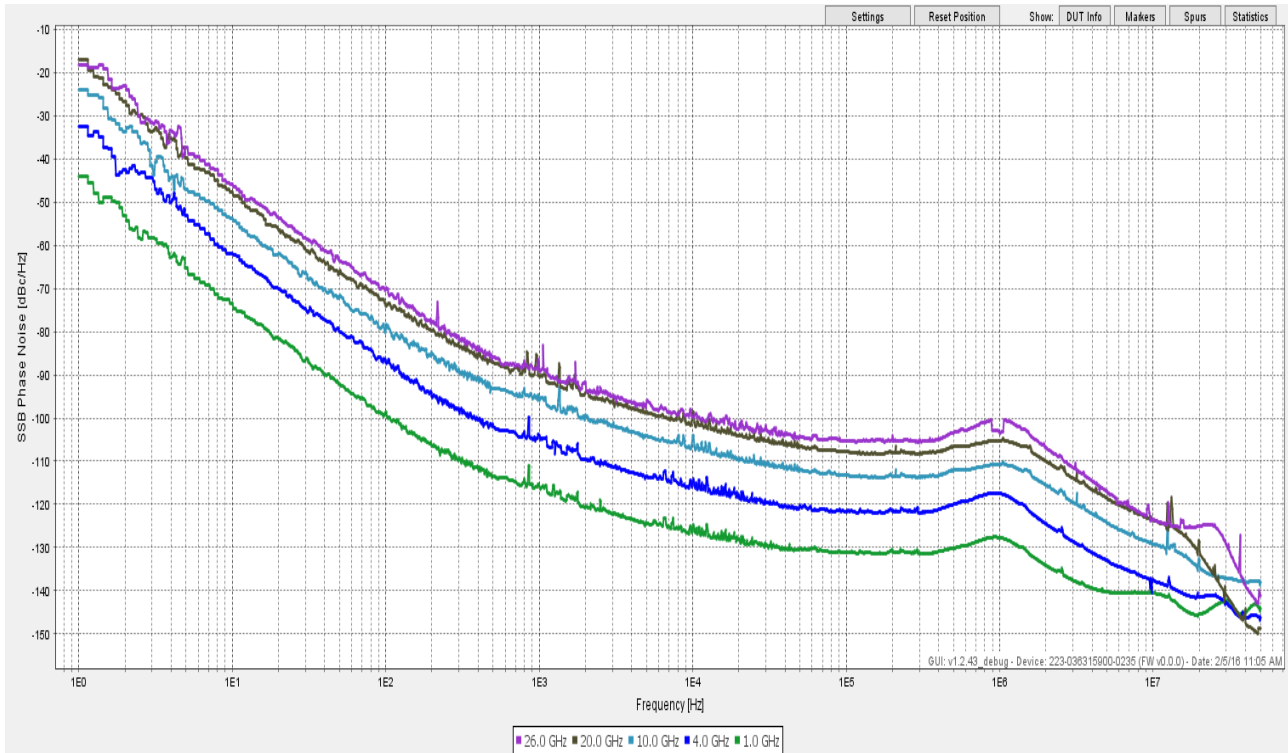

## Phase Noise with Option LN

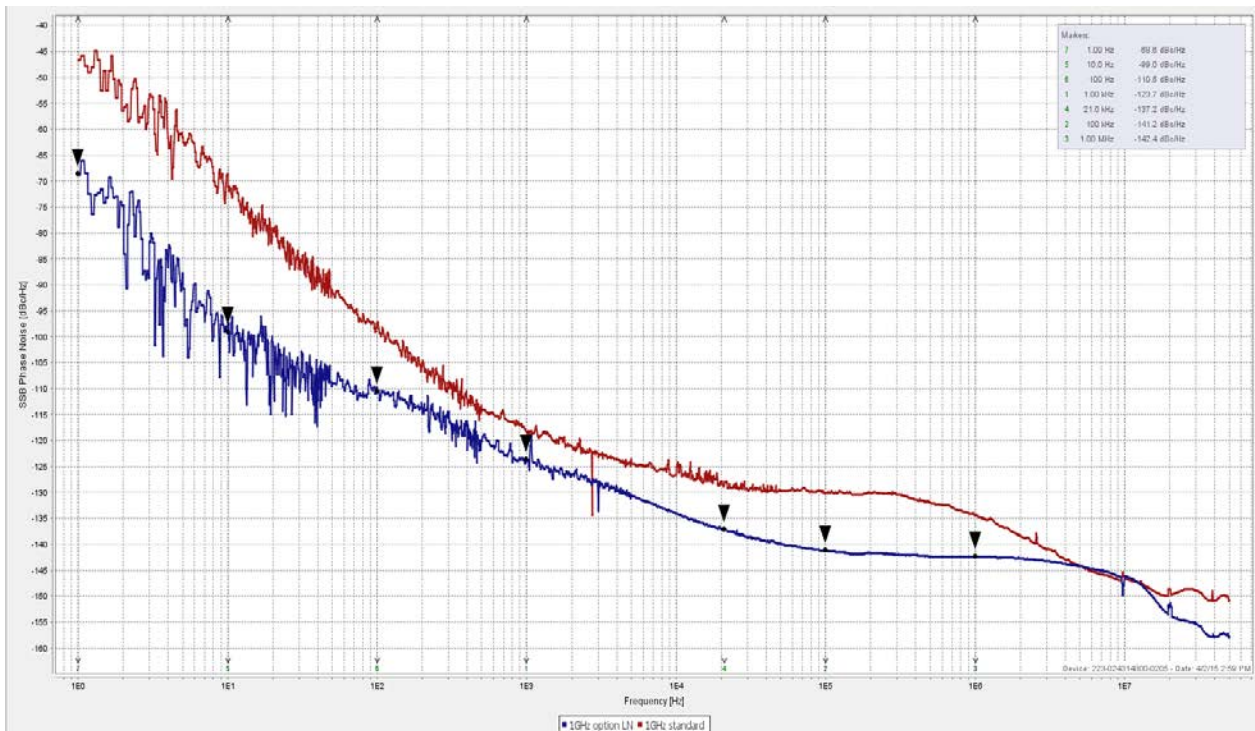

Typical Switching transient from 12 GHz to 14 GHz step

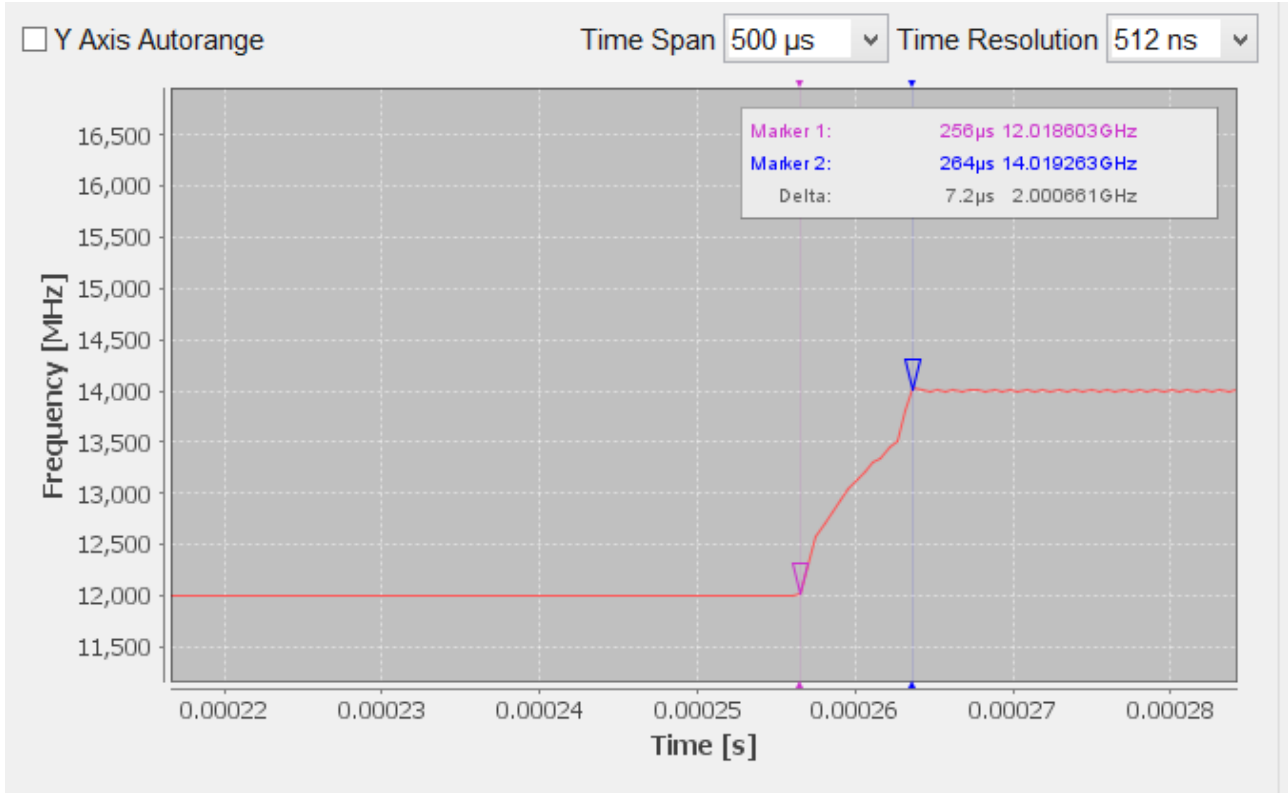

Typical Frequency Response 0 to 20 GHz at -20, 0, and +20 dBm

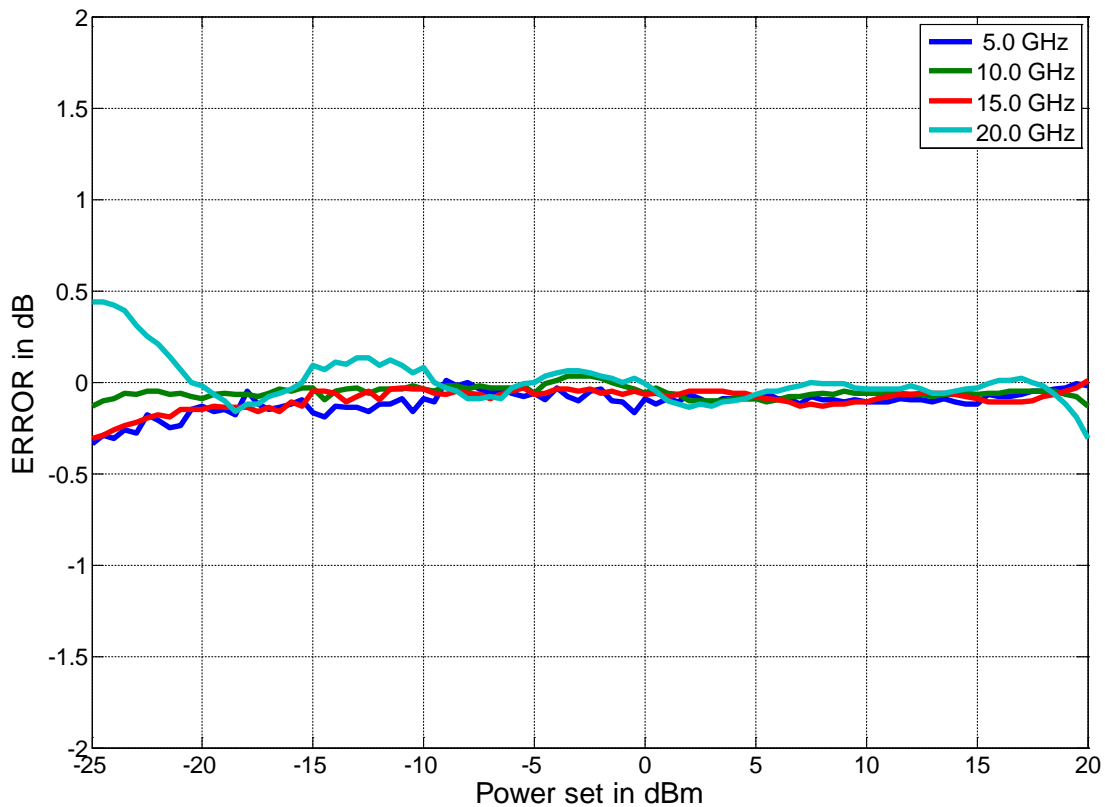
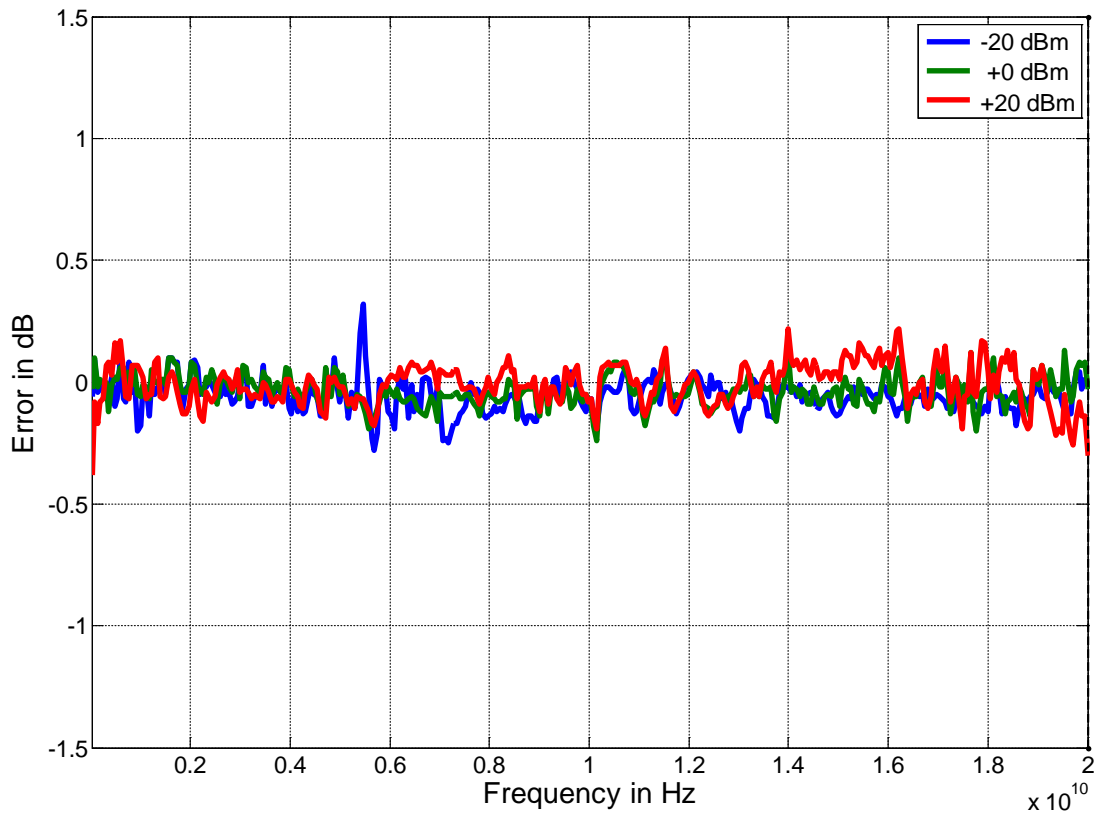

## Typical Maximum Output Power (standard)

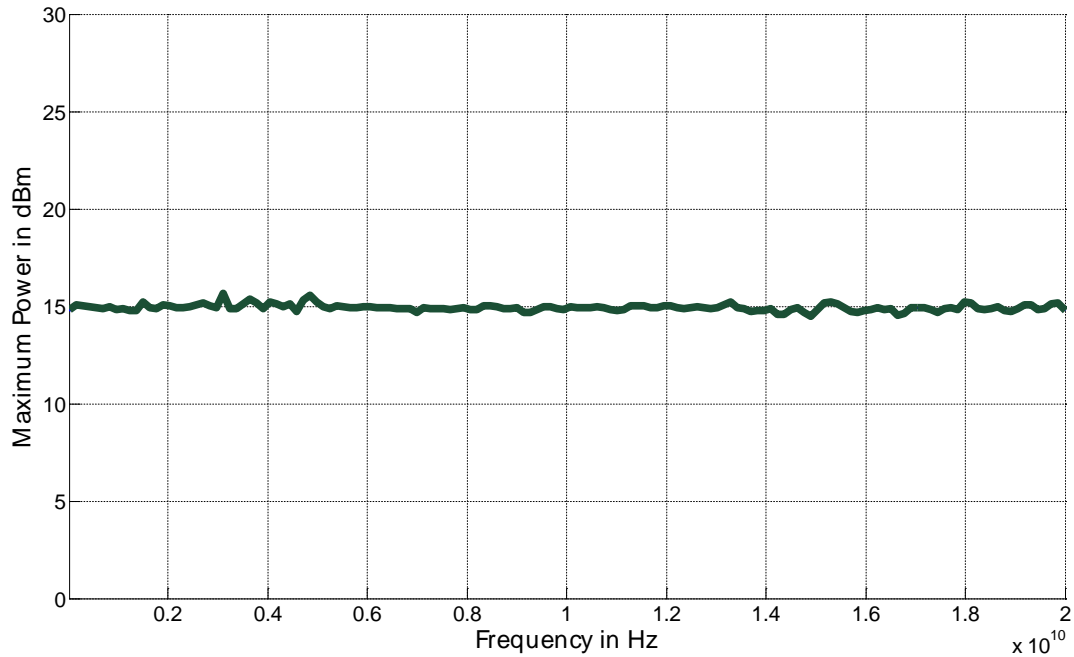

## Typical Maximum Output Power (option HP)

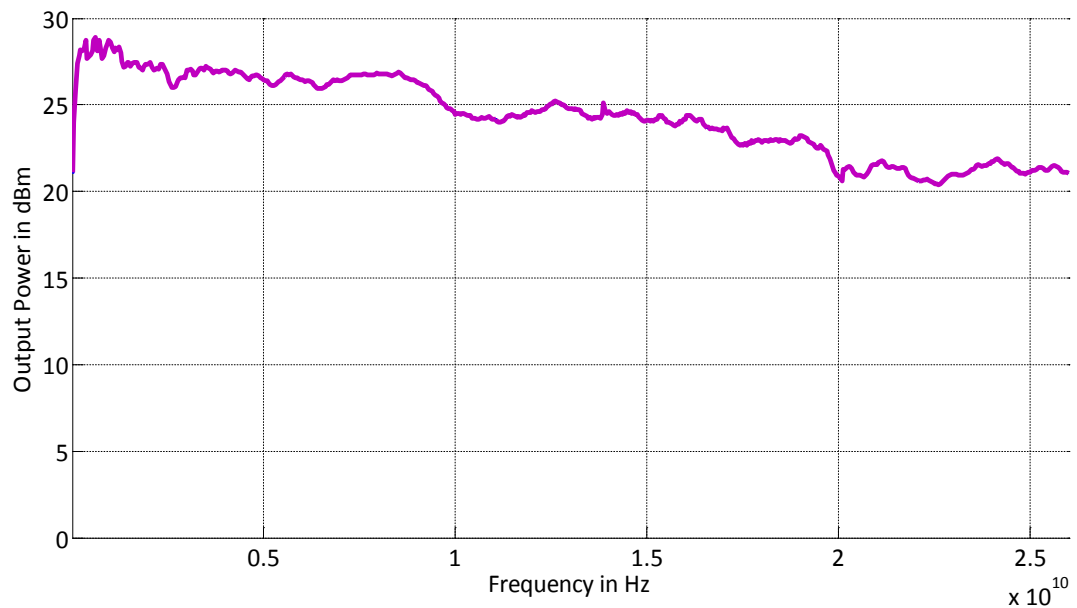

## Typical Maximum Output Power (options PE and HP)

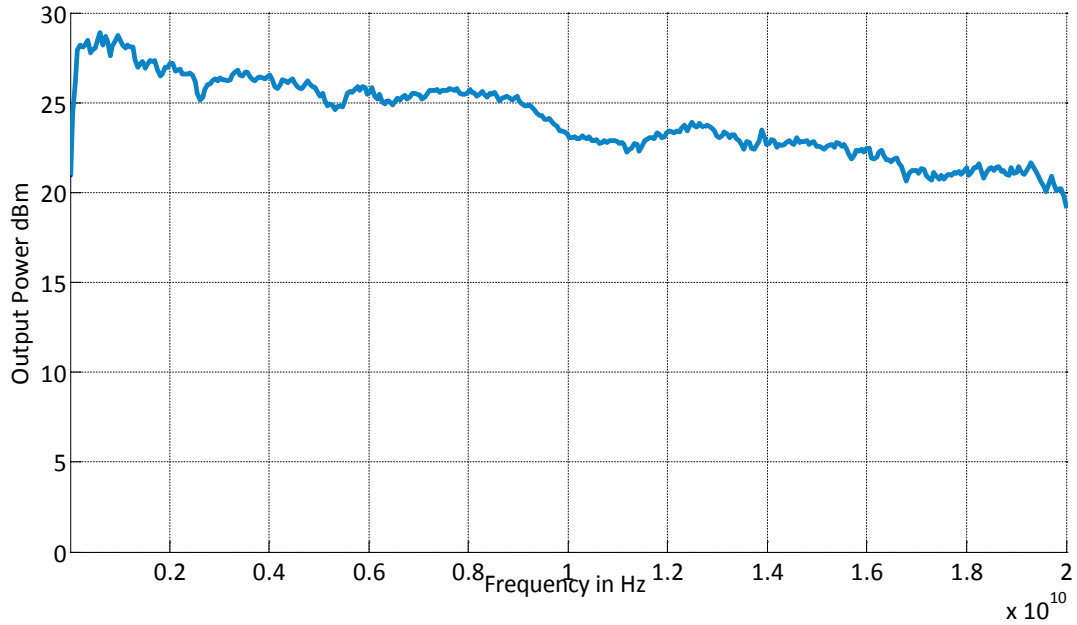

## Harmonics (with option PE)

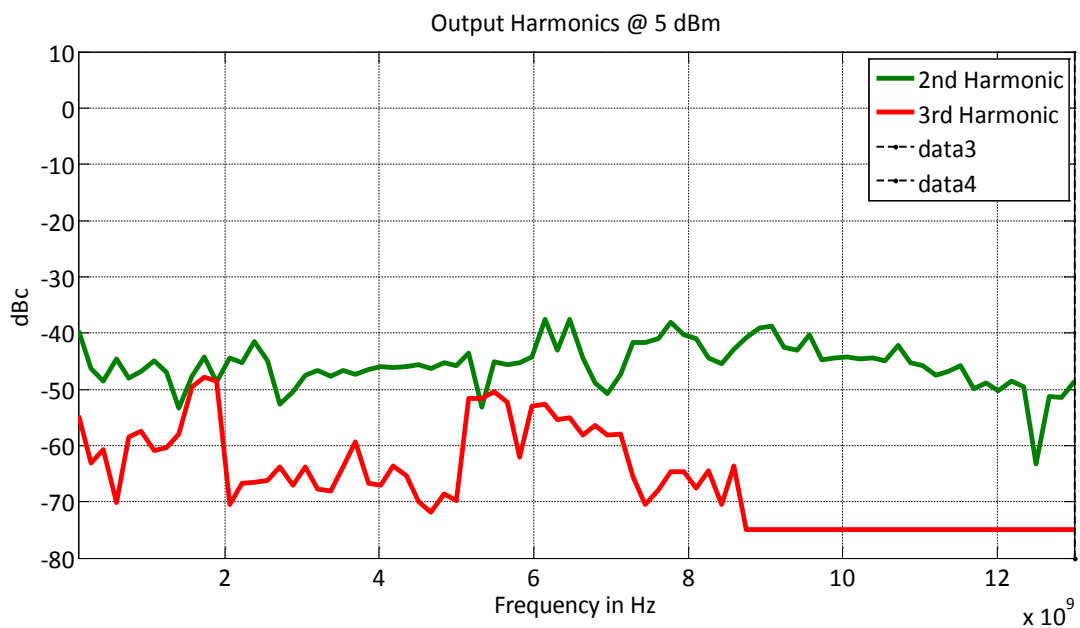

## Connectors

Front panel:

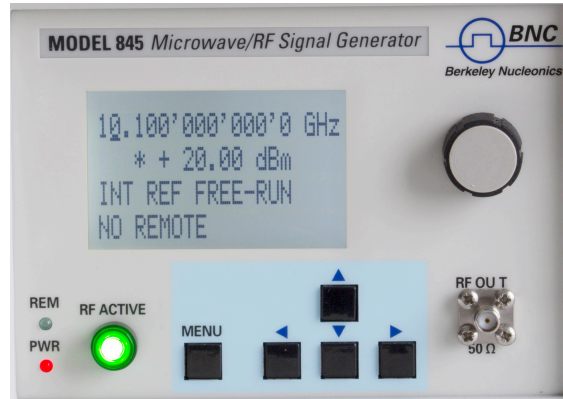

1. RF output: SMA female
2. RF on/off button
3. Rotary knob
4. Menu and  $\downarrow \uparrow \leftarrow \rightarrow$  arrow keys

Rear panel:

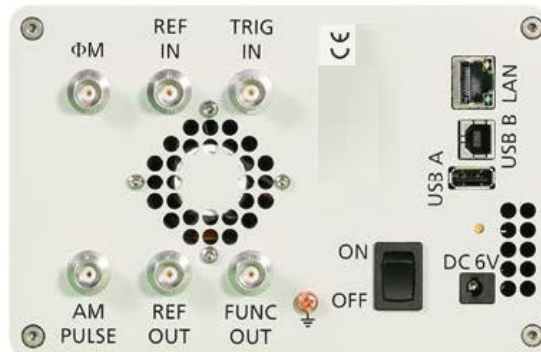

1. Trigger input: BNC female
2. Function output: BNC female
3. External reference input: BNC female
4. Internal reference output: BNC female
5. FM/PM modulation input: BNC female
6. AM and Pulse modulation: BNC female
7. LAN connection: RJ-45
8. USB 2.0 host and device
9. GPIB: IEEE-488.2, 1987 with listen and talk (optional)
10. DC Power plug (6V, 6A)
11. DC power switch

## General Characteristics

### Remote programming interfaces

Ethernet 100BaseT LAN interface,  
USB 2.0 host & device  
GPIB (IEEE-488.2,1987) with listen and talk (optional)  
Control language SCPI Version 1999.0

**Power requirements** 6.25 ± 0.2 VDC ; 20 W maximum

**Mains adapter supplied:** 100-240 VAC in/ 6 V 6.0 A DC out

**Operating temperature range** 0 to 40 °C

**Storage temperature range** -40 to 70 °C

**Operating and storage altitude** up to 15,000 feet



Safety/EMC complies with applicable Safety and EMC regulations and directives.

**Weight** ≤ 2.5 kg (6 lbs) net, ≤ 4 kg (8 lb.) shipping

**Dimensions** 106 mm H x 172 mm W x 270 mm L (incl. connectors)  
[4.21 in H x 6.77 in W x 10.63 in L]

**Recommended calibration cycle** 24 months

## Options

- **HP:** High output power
- **PE:** Extended power range down to <-90 dBm) step attenuator module
- **LO:** remove modulation
- **LN:** ultra low phase noise, improved frequency stability
- **FS:** enhanced switching speed
- **RB:** battery module
- **TP:** 3HE enclosure with touch display
- **R:** 19" 1HE enclosure with rack-mount capability. **Dimensions** 42 mm H x 426 mm W x 360 mm L [1.7 in H x 16.8 in W x 14.2 in L]